

# AFCO Installation & Operation Instructions

## Model #AF 912050 • W-50SS Spray-All

### REQUIREMENTS

#### Chemical Concentrate

<b>Water</b>	
Temperature	up to 180°F
Pressure	125 - 350 PSI
Flow	5.6 GPM @ 250 PSI
Supply Line	3/4"

**Hose** 1/2" x 50'

**Nozzle** Trigger Gun, 1/2"

### OPTIONS

**Large Stainless Steel Hose Rack** # 224150

**Stainless Steel Jug Racks**  
2 ½ Gallon (8 ½" x 10 ½") # 224210

5 Gallon (12" x 12") # 224215

5 Gallon Round Locking # 224216

**Lid & Suction Hose for 1 & 5 Gallon Pails**  
Pail Lid Suction Hose Assembly # 709101

**Alternate Check Valve - EPDM Standard**  
Check Valve, Chemical, SS, Viton, 1/4" # 491324-V



<http://www.afcocare.com>

**READ ALL  
INSTRUCTIONS BEFORE  
USING EQUIPMENT!**

## Overview

The W-50SS Spray-All is a water-driven, high volume spray applicator for applying chemical solutions to a variety of surfaces. This stainless steel venturi injection system uses boosted water pressure (125 - 350 PSI) to draw and blend chemical concentrate into the water stream using precision metering tips. The accurately diluted solution is then projected through the discharge hose and adjustable spray pattern trigger gun as a powerful, "flooding spray" for applying sanitizers or other chemicals.

AFCO • 5000 Letterkenny Rd • Chambersburg, PA. 17201 • 1-800-345-1329



## Safety & Operational Precautions

- For proper performance do NOT modify, substitute nozzle, hose diameter or length.
- Manufacturer assumes no liability for the use or misuse of this unit.
- Wear protective clothing, gloves and eye wear when working with chemicals.
- Always direct the discharge away from people and electrical devices.
- Follow the chemical manufacturer's safe handling instructions.

### TO INSTALL (REFER TO DIAGRAM, NEXT PAGE.)

1. Mount the unit to a suitable surface above the chemical supply to prevent siphoning.
2. Connect the discharge hose as shown in the diagram.
3. To prevent blocking the small water jets in the injector flush any new plumbing of debris before connecting water.
4. Connect water supply. If water piping is older or has known contaminants install a water filter.

### Set the chemical dilution ratio by threading one of the color coded metering tips into each chemical check valve. See chemical labels for dilution ratio recommendation or consult your chemical supplier.

- For the strongest dilution ratio do NOT install a colored metering tip.
- The dilution ratios in the metering tip chart are based on water thin chemicals with a viscosity of 1CPS.
- **Thicker chemicals will require a larger tip than the ratios shown in the chart.**
- Application results will ultimately determine final tip color.
- Select the tip color that is closest to your desired chemical strength and thread it into the tip holder. **DO NOT OVER TIGHTEN.**
- Push the chemical tube over the check valve barb and place the strainer in the chemical concentrate.

### TO OPERATE

1. Make final metering tip adjustments based on application results.
2. With trigger gun in hand open the inlet ball valve.
3. Pull the trigger and begin application.
4. When application is completed, release the trigger then close the inlet ball valve.
5. Briefly squeeze the trigger to relieve pressure in hose.

#### Metering Tip Selection Chart

Metering Tip Color	Oz. per Min.	Example: Dilution Ratio @ 300 PSI
Brown	.56	1284:1
Clear	.88	817:1
Bright Purple	1.38	521:1
White	2.15	334:1
Pink	2.93	245:1
Corn Yellow	3.84	187:1
Dark Green	4.88	147:1
Orange	5.77	125:1
Gray	6.01	120:1
Light Green	7.01	103:1
Med. Green	8.06	89:1
Clear Pink	9.43	76:1
Yellow Green	11.50	63:1
Burgundy	11.93	60:1
Pale Pink	13.87	52:1
Light Blue	15.14	47:1
Dark Purple	17.88	40:1
Navy Blue	25.36	28:1
Clear Aqua	28.60	25:1
Black	50.00	14:1
No Tip Ratio	up to 7.0:1	

The dilution ratios above are approximate values. Due to chemical viscosity, actual dilution ratios may vary.

#### Metering Tip Selection Formula

$$\frac{(\text{GPM} \times 128)}{\text{Dilution Ratio}} = \text{Oz. per Min}$$

#### Flow Rate Chart

Pressure	Flow Rate
PSI	GPM
150	4.35
200	5.02
250	5.62
300	6.15
350	6.64

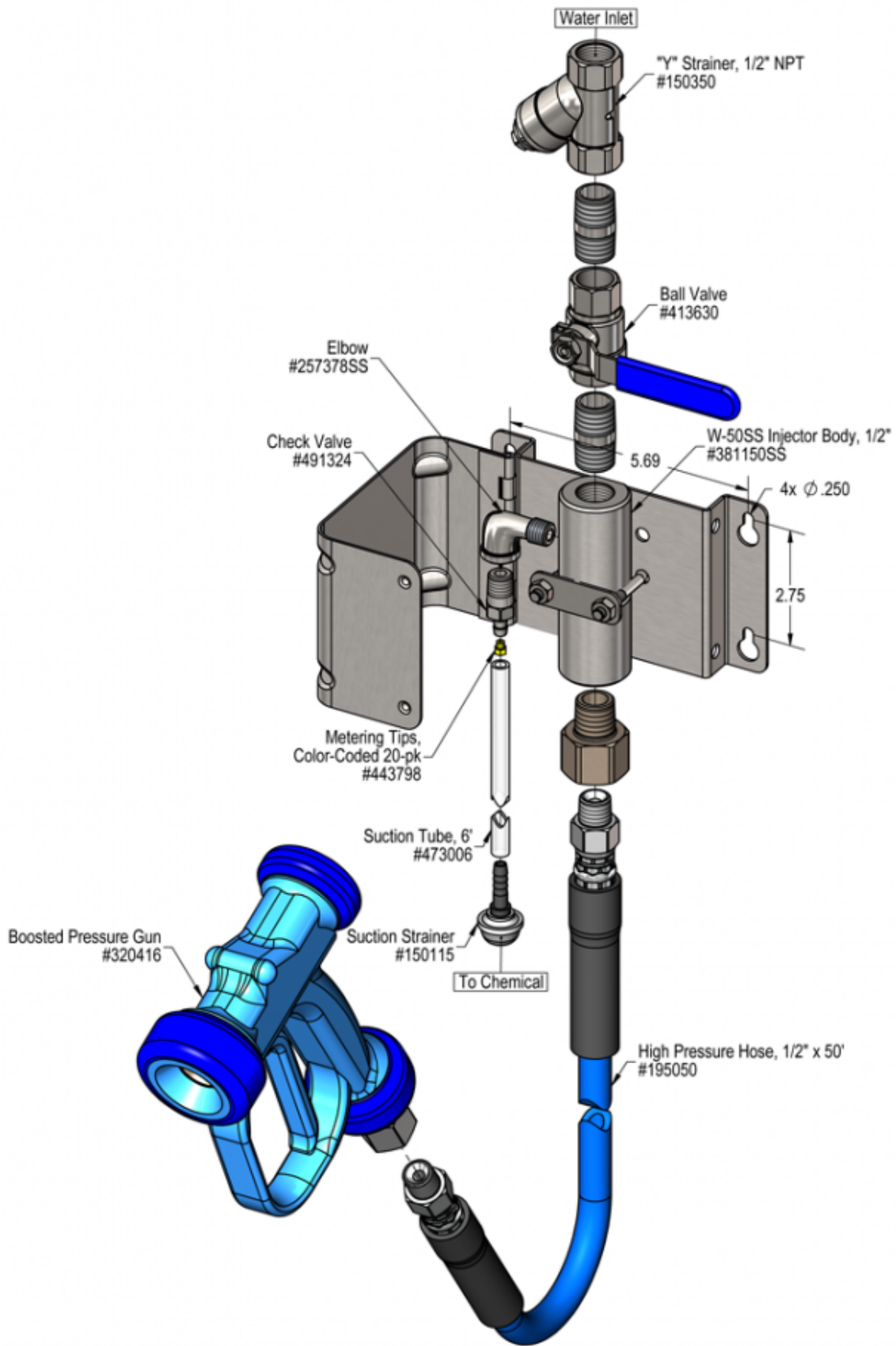

# Troubleshooting Guide

## AF 912050 • W-50SS Spray-All

Problem	Possible Cause / Solution	
	Startup	Maintenance
A) Unit will not draw chemical	1, 4, 5, 6, 7	8, 9, 10, 11, 12, 13, 14
B) Dilution too weak	2, 4, 5	8, 9, 10, 11, 12, 13, 14
C) Dilution too strong	3	14
D) Water backing up into chemical container		8

Possible Cause / Solution	
Startup	Maintenance
<ol style="list-style-type: none"> <li>1. <b>Inlet ball valve or trigger gun not completely open</b> <ul style="list-style-type: none"> <li>◦ Completely open the inlet ball valve.</li> </ul> </li> <li>2. <b>Not enough chemical - metering tip too small</b> <ul style="list-style-type: none"> <li>◦ Install larger metering tip.</li> </ul> </li> <li>3. <b>No metering tip installed or metering tip too large</b> <ul style="list-style-type: none"> <li>◦ Install smaller metering tip.</li> </ul> </li> <li>4. <b>Chemical tube not immersed in chemical or chemical depleted</b> <ul style="list-style-type: none"> <li>◦ Immerse tube or replenish.</li> </ul> </li> <li>5. <b>Discharge hose too long for available water pressure, kinked or wrong size</b> <ul style="list-style-type: none"> <li>◦ Straighten the hose or replace hose.</li> </ul> </li> <li>6. <b>Nozzle size too small (SEE REQUIREMENTS)</b></li> <li>7. <b>Water pressure or water volume too low/inlet piping too small causing poor chemical pick up</b> <ul style="list-style-type: none"> <li>◦ Increase water pressure or water volume</li> </ul> </li> </ol>	<ol style="list-style-type: none"> <li>8. <b>Chemical check valve stuck or failed</b> <ul style="list-style-type: none"> <li>◦ Clean or replace.</li> </ul> </li> <li>9. <b>Chemical strainer or metering tip partially blocked</b> <ul style="list-style-type: none"> <li>◦ Clean or replace chemical strainer and/or metering tip.</li> </ul> </li> <li>10. <b>Chemical tube stretched out or pin hole/cut in chemical tube</b> <ul style="list-style-type: none"> <li>◦ Cut off end of tube or replace tube.</li> </ul> </li> <li>11. <b>Vacuum leak in chemical pick-up connections</b> <ul style="list-style-type: none"> <li>◦ Tighten the connection.</li> </ul> </li> <li>12. <b>Water strainer clogged or missing/injector inlet orifice clogged</b> <ul style="list-style-type: none"> <li>◦ Clean or replace strainer; check/clean inlet orifice for obstructions. DO NOT DRILL OUT.</li> </ul> </li> <li>13. <b>Hard water scale or chemical build-up may have formed in the injector body causing poor or no chemical pick-up</b> <ul style="list-style-type: none"> <li>◦ Follow Preventive Maintenance instructions below, using hot water and/or de-scaling acid. When there is no draw at all, carefully remove fittings and soak entire injector body in de-scaling acid.</li> </ul> </li> <li>14. <b>More than one chemical ball valve is open</b> <ul style="list-style-type: none"> <li>◦ 2-Way and 3-Way models only</li> </ul> </li> </ol>

**PREVENTIVE MAINTENANCE:** When the unit will be out of service for extended periods, place chemical tube(s) in water and flush the chemical out of the unit to help prevent chemical from drying out and causing build-up. Periodically check and clean chemical strainer and replace if missing.

